

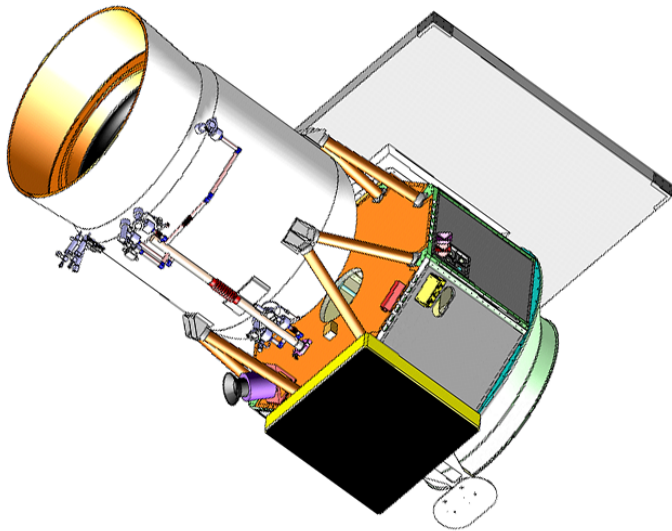

Widefield Infrared Survey Explorer



Science Objectives

WISE will provide an all-sky survey from 3 to 25 μm with 500,000 times the sensitivity of COBE/DIRBE and 500 times that of IRAS. The survey will help search for the origins of planets, stars, and galaxies and create an infrared atlas for the James Webb Space Telescope.

WISE will:

- Find the most luminous galaxies in the Universe.
- Find the closest stars to the Sun.
- Detect most Main Belt asteroids larger than 3 km.
- Enable a wide variety of studies ranging from the evolution of protoplanetary debris discs to the history of star formation in normal galaxies.
- Provide an important source catalog for JWST

Mission Overview

Launch: 2009

- Direct injection launch on a Delta II rocket into a circular, 500-km, Sun-synchronous orbit.
- 7-month mission including a 1-month checkout.
- Sky-pointing instrument.
- 11-second data-taking exposure cycle synchronized with orbit to provide total sky coverage with overlap between revolutions.
- 8 or more exposures at each position over more than 99% of the sky

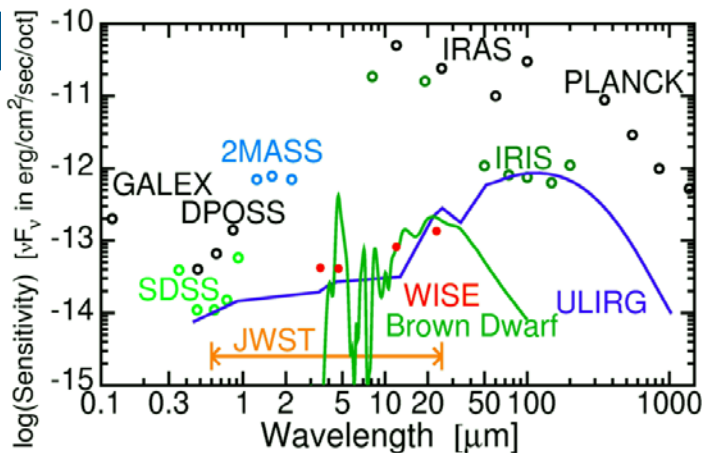
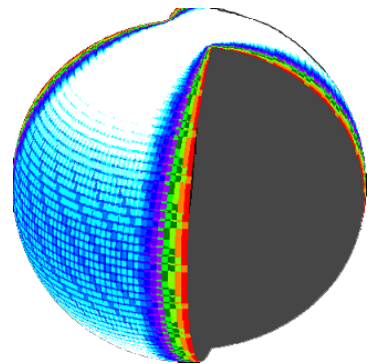
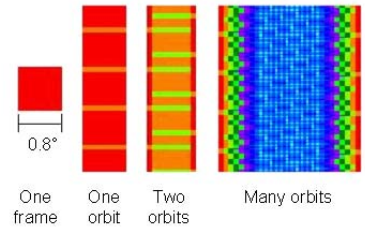

Science Payload

- HgCdTe and Si:As 1024^2 detector arrays at 3.3, 4.7, 12, and 24 μm .
- A two-stage solid-hydrogen cryostat to cool focal planes and optics.
- A 40-cm telescope and reimaging optics.
- A scan mirror to stabilize the line-of-sight while the spacecraft scans the sky.

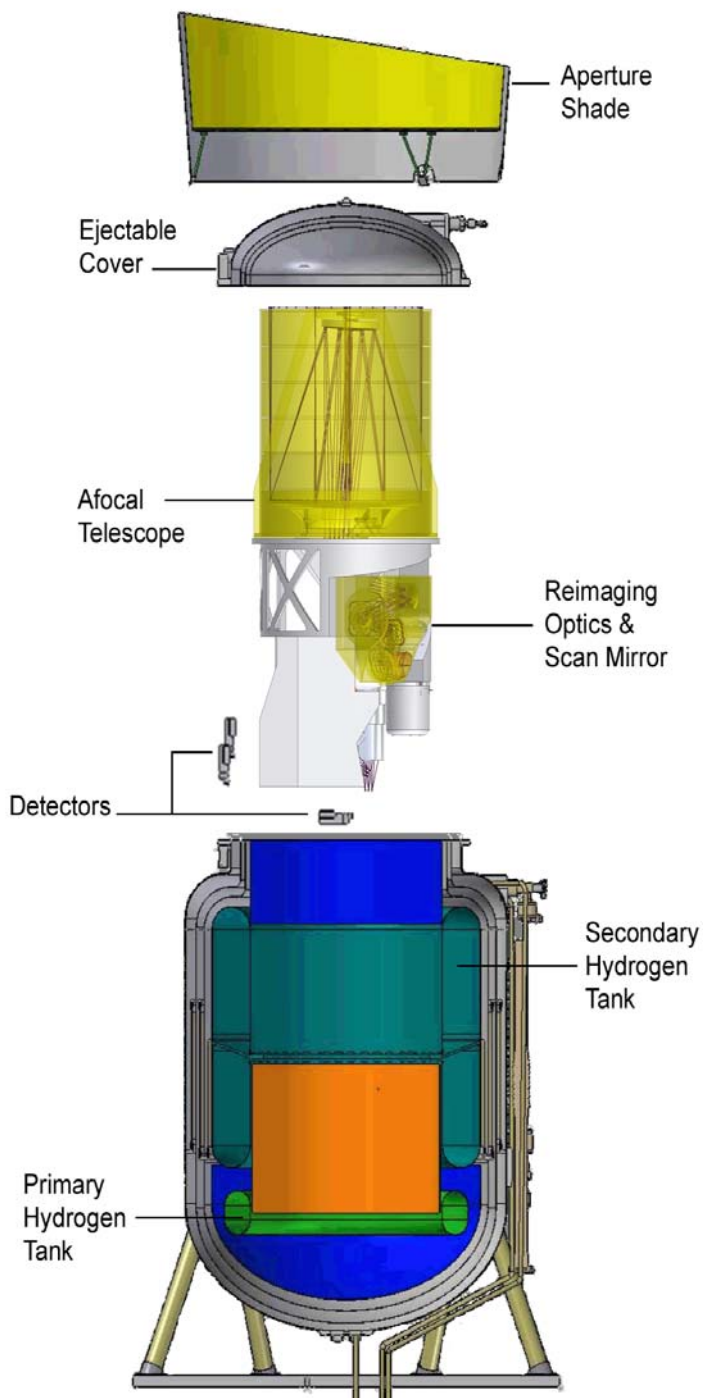

Mission Management

The Principal Investigator for WISE is **Edward Wright** of UCLA, data team head for COBE and MAP, and interdisciplinary scientist for Spitzer. The WISE Science Team includes world leaders in ULIRGs (Ultra-Luminous Infrared Galaxies), Brown Dwarfs, IR instrumentation, JWST, and all-sky survey design and data processing.

JPL is responsible for project management, system engineering, mission operations, and mission assurance.

Complementing the science team are industry and university team members selected for their expertise in each area:

Space Dynamics Lab

Instrument Systems

Engineering, Electronics, and Testing

DRS, Rockwell

Focal Planes

Lockheed Martin

Cryostat

SSG

Telescope, Optics, Scan Mirror

Ball Aerospace

Spacecraft, System Testing, Operations

IPAC/Caltech

Data Processing and Archiving

UC Berkeley

Education & Public Outreach

Education and Public Outreach

A nationwide partnership led by UC Berkeley, the WISE E/PO program includes asteroid searches, 3-D Milky Way visualization, and science modules for grades 6 – 12.

